

DIPLOMA IN CNC PROGRAMMING

Learn CNC Programming

Who can do?

- Matriculated Passed Candidates
- Engineering Students
- Mechanical Diploma Holders
- Mechanical Technical Assistance
- Machine Operators
- Those people who would like to develop their skills regarding CAD/CAM and CNC Programming

**100,000+ Students
have been Trained**

since
1997

**Program is
offered by**

**3D EDUCATORS
INTL**
22 Years of
Excellence in
Training &
Development

**Invest in
People the
only Asset
that Appreciates**



100,000+ Students
have been Trained

since
1997



Diploma in CNC Programming

Table of Content

Detail

Inauguration

Structure

Topics & Time Allocation

About the Program Designer & Instructor

Syllabus



100,000+ Students
have been Trained

since
1997



Diploma in CNC Programming

Program Details

Inauguration

The Training Program will be inaugurated by a senior member of 3DEducators

Program Structure

No of classes per week	01 Class
Duration of each class	02 - Hour
Total Duration	64 Hours

Other Learning Activities

Classroom Assignments	32
Presentations by Trainees	01
Case Studies	02

About the Program Instructor

DIPLOMA IN CNC Programming is the course which start from the scratch and covers the CNC 3 Axis programming with machine operations. All the courses shall be conducted by senior consultants and engineering who have the extensive experience relates to different national and multinational organization

- ✓ Senior Mechanical CAD Engineers
- ✓ Senior Mechanical CNC Programmers

Well qualified and experienced trainers with extensive hands-on and experience to groom the candidates to develop the CAD/CAM and CNC skills

In Affiliation with





100,000+ Students
have been Trained

since
1997



Diploma in CNC Programming

Program Syllabus

Major Courses of Program

The structure of the training is as follows:

The Program Consist on following major courses

1. AutoCAD 2D/3D Mechanical
2. CAD Modelling on CREO
3. 2- 3 Axis CNC Programming
4. Master CAM Software for CAM Machining and Operation
5. 5 Axis CNC Programming



100,000+ Students
have been Trained

since
1997



Diploma in CNC Programming

AutoCAD 2D/3D

Chapter 1: AutoCAD Mechanical Design Concepts

- AutoCAD Mechanical Overview
- Mechanical Structure
- Standard Based Design
- Dimension Productivity Tools
- Dimension and Annotation
- Production Drawing Creation
- Standard Content
- Machinery Generators
- Calculation Tools
- Autodesk Inventor Linked Models
- Configuration and Setup Guide

Chapter 2: User Interface

- Interacting with User Interface
- Common Drawing Setup

Chapter 3: Mechanical Structure

- Structuring Data in Drawings
- Reusing and Editing Structured Data
- Structure and Other Tools

Chapter 4: Mechanical Layers and Layer Control

- Layers
- Layer Control

Chapter 5: Tools for Creating Key Geometry Power Snaps

- Core Design Tools
- Centerlines
- Construction Lines
- Designing with Lines
- Adding Standard Feature Data for Holes and Slots

Chapter 6: Tools for Manipulating Geometry

- Editing Tools
- Power Commands

Chapter 7: Mechanical Part Generators

- Standard Parts
- Springs
- Chain/Belt
- Shaft Generators
- Standard Shaft Parts

Chapter 8: Creating Drawing Sheets

- Model Space Views in Layouts
- Title Block and drawing Borders
- Creating Drawing Sheets in Model Space



Diploma in CNC Programming

100,000+ Students
have been Trained

since
1997



Chapter 9: Dimensioning and Annotation Your Drawings

- Creating Dimensions
- Editing Dimensions
- Hole Charts and Fits Lists
- Annotation and Annotation Symbols
- Revision Lists

Chapter 10: Bill of Materials, Parts Lists, and Balloons

- Bill of Materials
- Inserting Parts Lists
- Ballooning Parts

Chapter 11: Design Calculations

- Moment of Inertia
- Moment of Inertia with Predefined Profiles
- Deflection Line
- Shaft Stresses
- The Finite Element Analysis

Chapter 12: Working Without Structure

- Layer Groups
- Part references
- 2D Hide
- Library

Chapter 13: Mechanical Options for the CAD Manager

- Standard Based Design
- Configure Layer, Text, and Symbol
- Properties Configure the BOM, Parts List, and Balloons Configure the Annotation Tools



100,000+ Students
have been Trained

since
1997



Diploma in CNC Programming

COMPUTER AIDED DESIGN (CREO MODELLING)

PTC Creo Parametric

PTC CREO Parametric is a parametric modeling system that provides the powerful 3D CAD capabilities to create challenging design products. It uses proven technologies from Pro/ENGINEER and other hundreds of new capabilities for design productivity.

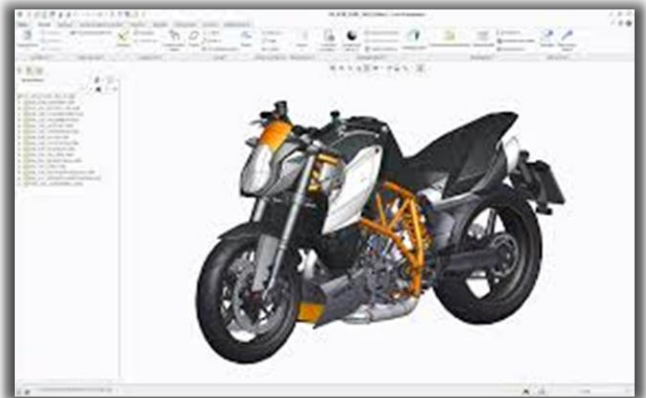

Reasons to Upgrade from Pro/ENGINEER to PTC Creo Parametric

PTC CREO Parametric provides powerful, reliable & easy to use modeling tools that accelerate the product design process. There are different versions of PTC software that have different capabilities. Every new version of PTC software has enhanced revolution with great capabilities. There are top ten enhanced capabilities that attract PTC users to shift from Pro/ENGINEER to PTC CREO



Diploma in CNC Programming

100,000+ Students
have been Trained

since
1997



1. Enhanced User Interface

PTC CREO Parametric has an enhanced user interface that is suitable for those who are using Pro/ENGINEER. User doesn't feel uncomfortable during work and feel similar to Pro/ENGINEER but with power full easy to use environment.

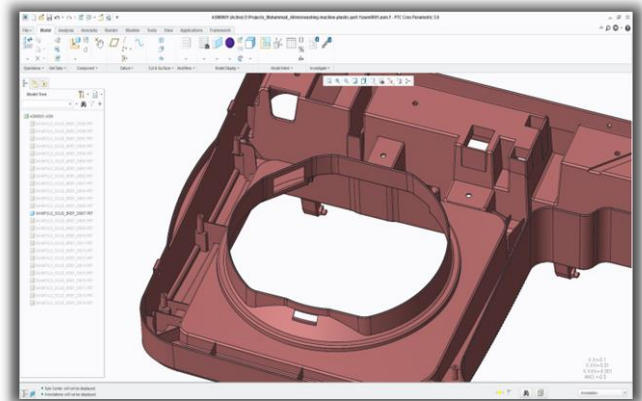

2. Industry-Leading User Experience

PTC CREO Parametric has revolutionized user interface that is similar to world leading Microsoft products. In Previous versions of Pro/Engineer, user felt uncomfortable during opening a lot of menus to activate just a single command. But now it is converted to ribbon user interface with a lot of command buttons.

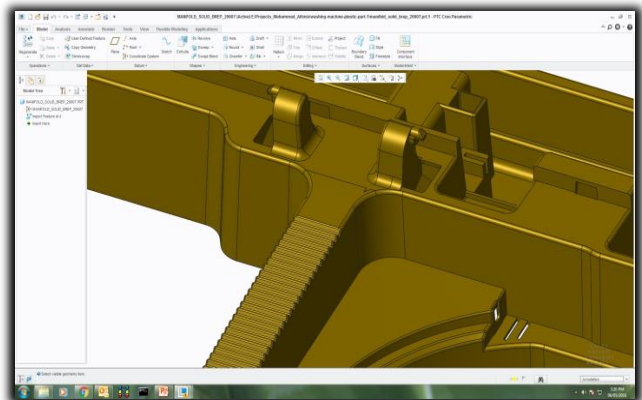



Diploma in CNC Programming

100,000+ Students
have been Trained

since
1997



3. Flexibility In Designing

PTC Creo Parametric has added flexibility in designing of complex freeform shapes with easy to use environment. The user feels relaxation in creating complicated freeform surfaces & shapes which were difficult and time consuming in previous versions of Pro/ENGINEER.

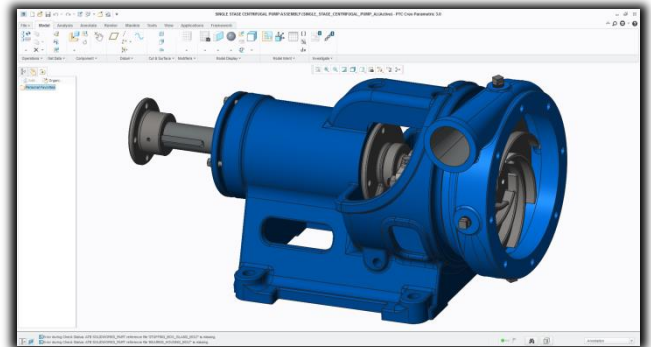

4. 2D Conceptual Designing

PTC Creo Parametric has converted it's 2D sketching environment like a free hand sketch. The user can create complex 3D models & surfaces using power full 2D sketcher. The user directly sketch on to a photo like tracing to create complex 3d shapes with easy to use environment.

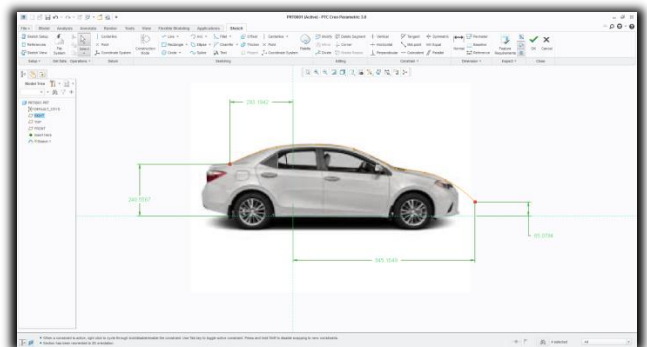



100,000+ Students
have been Trained

since
1997



Diploma in CNC Programming

5. Fast Sketching Productivity

PTC Creo Parametric is revolutionary enhanced in creating fastest 3D model. The user now can create & change complex 3d features quickly which are fully parametric. Every command like extrude, revolve, sweep etc. was not easy in previous versions of Pro/ENGINEER as are in PTC Creo Parametric.

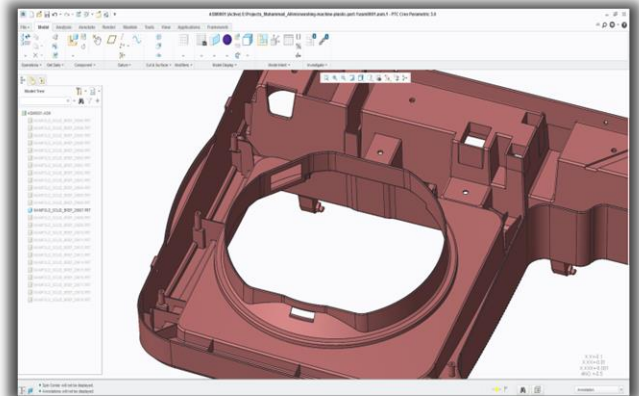

6. Fast 3D Modeling

PTC Creo Parametric has added more enhancements in core designing. The user now can create 3D part model faster than previous versions of Pro/ENGINEER. Many complex geometry commands like parallel blend, rotational blend, helical sweep etc. have additional controls & options to create complex 3D models.

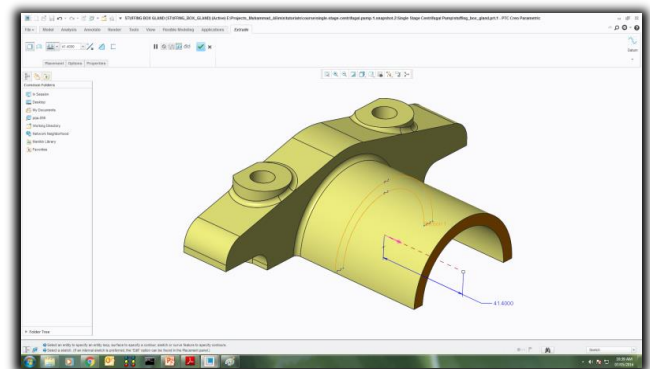



100,000+ Students
have been Trained

since
1997



Diploma in CNC Programming

7. 3D Measurement

PTC Creo Parametric provides an intelligent 3D measuring tool. The user can create & measure 3D model with relevant geometric information like area, volume, distance, diameter etc. with a new enhanced environment.

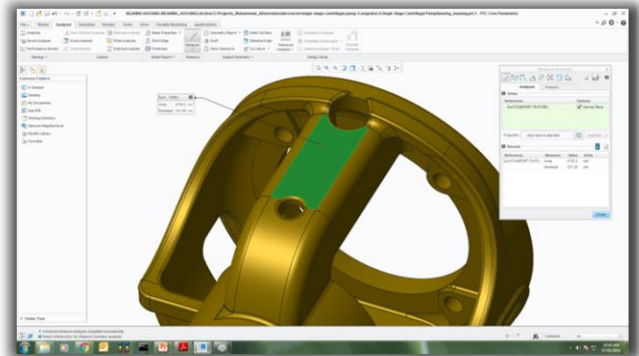

8. Sheet metal Efficiency

PTC Creo Parametric has now industry leading capabilities in sheet metal module. The user can make complicated sheet metal components with easy to use enhanced tools & commands that never were in previous versions of Pro/ENGINEER. All features that are used in sheet metal like bend, flange, sketch based form etc. are very robust and powerful.

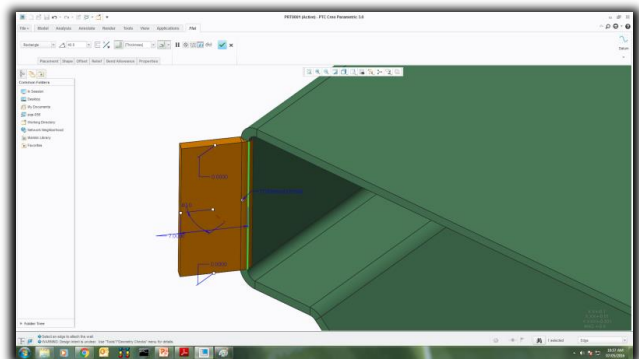



Diploma in CNC Programming

100,000+ Students
have been Trained

since
1997



9. Assembly Revolution

PTC Creo Parametric is truly parametric software that updates every part in an assembly even a mere change occurred in designing. The user can create 3D sectioning in an easy way and if any problem occurs then PTC Creo performs real-time interference checking of all parts within the assembly.

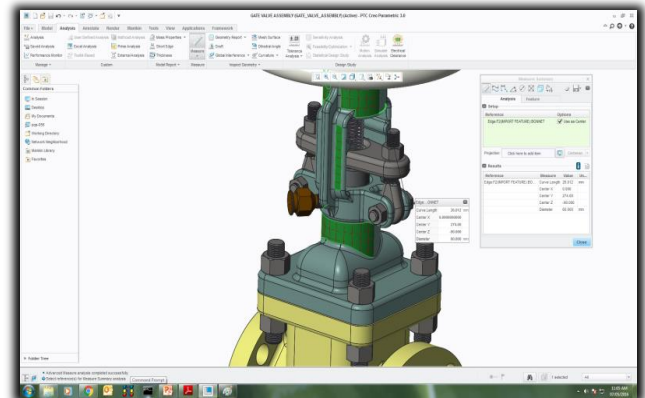

10. Massive Assembly

PTC Creo Parametric is completely different than Pro/ENGINEER. The user can work on massive assembly faster up to 40 times. Component placement constraints & 3D dragger provide us powerful command to make massive assemblies with great performance.

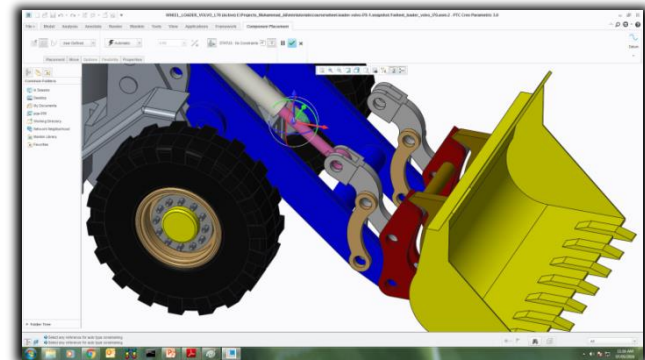



100,000+ Students
have been Trained

since
1997



Diploma in CNC Programming

COURSE LAYOUT

1	Introduction to the Creo Parametric Basic Modeling Process
2	Understanding Creo Parametric Concepts
3	Using the Creo Parametric Interface
4	Selecting Geometry, Features, and Models
5	Editing Geometry, Features, and Models
6	Creating Sketcher Geometry
7	Creating Sketches for Features
8	Creating Datum Features: Planes and Axes
9	Creating Extrudes, Revolves, and Ribs
10	Creating Sweeps and Blends
11	Creating Holes, Shells, and Draft
12	Creating Rounds and Chamfers
13	Group, Copy, and Mirror Tools
14	Creating Patterns
15	Measuring and Inspecting Models
16	Assembling with Constraints
17	Assembling with Connections
18	Exploding Assemblies
19	Drawing Layout and Views
20	Creating Drawing Annotations
21	Investigating Parent/Child Relationships
22	Resolving Failures
23	Making Project



100,000+ Students
have been Trained

since
1997



Diploma in CNC Programming

2D SKETCHING

- Datum Planes
- Line, segment line
- Reference line, Center line
- Spline
- Arc, Ellipse,
- Trim, Corner joining
- Circle, oval
- Square, Rectangle,
- Mirror
- Rotate
- Move
- Dimensioning
- Measurement
- Orientation Setting



100,000+ Students
have been Trained

since
1997



Diploma in CNC Programming

3D SOLID WORKING:

- Extrude
- Revolve
- Blend
- Boundary Blend
- Sweep
- Variable Section Sweep
- Helical Sweep
- Helical Cut
- Projection
- Round
- Shell
- Rib
- Hole Tool
- Chamfer
- Pattern

ADVANCE COMMANDS:

- Solid free from Surface
- Toroidal Bend
- Pipe

MANUFACTURING & PROGRAMMING:

- Workpiece Making
- Workpiece operation
- Tool set up
- Feed system
- Cutter Decision
- Machining with cutters
- Co-ordinate system



100,000+ Students
have been Trained

since
1997



Diploma in CNC Programming

MASTER CAM

1. Introduction to Mastercam

- Overview of Mastercam software and its applications
- Understanding the user interface and navigation
- Setting up preferences and configurations
- File management and data import/export

2. Basic Geometry Creation

- Drawing 2D geometry (lines, arcs, rectangles, etc.)
- Editing and modifying geometry
- Using construction planes and views
- Dimensioning and annotation

3. Toolpath Fundamentals

- Introduction to toolpaths and machining operations
- Selecting tools and defining tool parameters
- Setting up stock and work coordinates
- Basic 2D toolpaths (contour, pocket, drill, etc.)

4. 2D Machining

- Creating and simulating 2D toolpaths
- Using toolpath parameters (speeds, feeds, depths, etc.)
- Post-processing and generating G-code
- Practical examples and projects

5. 3D Geometry Creation

- Introduction to 3D modeling
- Creating and editing surfaces and solids
- Importing 3D models from other CAD software
- Working with wireframe geometry

6. 3D Machining

- Introduction to 3D toolpaths (roughing, finishing, etc.)
- Surface machining strategies (parallel, contour, radial, etc.)
- High-speed machining (HSM) toolpaths
- Multi-axis machining basics (4-axis and 5-axis)

7. Advanced Toolpaths and Techniques

- Dynamic milling and advanced roughing
- Rest machining and leftover material removal
- Custom toolpath creation using Mastercam's advanced features
- Toolpath optimization for efficiency and precision



100,000+ Students
have been Trained

since
1997



Diploma in CNC Programming

8. Lathe and Mill-Turn Machining

- Introduction to Mastercam Lathe
- Creating and simulating lathe toolpaths
- Mill-Turn machining for complex parts
- Practical examples and projects

9. Multi-Axis Machining

- Introduction to 4-axis and 5-axis machining
- Creating and simulating multi-axis toolpaths
- Advanced multi-axis strategies (swarf, curve, etc.)
- Post-processing for multi-axis machines

10. Simulation and Verification

- Using Mastercam's built-in simulation tools
- Verifying toolpaths for errors and collisions
- Analyzing machining time and efficiency
- Exporting simulations for documentation

11. Post-Processing and CNC Machine Integration

- Understanding post-processors and their role
- Customizing post-processors for specific machines
- Transferring G-code to CNC machines
- Troubleshooting and debugging G-code

12. Practical Projects and Applications

- Hands-on projects for 2D and 3D machining
- Real-world applications and case studies
- Best practices for efficient CNC programming
- Tips and tricks for mastering Mastercam

13. Advanced Topics (Optional)

- Customizing Mastercam with APIs and scripting
- Integrating Mastercam with other CAD/CAM software
- Exploring additive manufacturing and hybrid machining
- Industry-specific applications (aerospace, automotive, etc.)

14. Certification and Assessment

- Review of key concepts and skills
- Practical assessment and project submission
- Preparation for Mastercam certification exams (if applicable)



100,000+ Students
have been Trained

since
1997



Diploma in CNC Programming

CNC 5 AXIS PROGRAMING

- Job calling in manufacturing (calling of ref Model)
- Set orientation of model
- Creation of work piece
- Addition of work piece in ref model
- Define work center
- Define CNC control
- Define number of axis (3 to 5)
- Addition of fixture as per requirement
- Setting of operation
 - Setting machine to zero
 - Define Clearance



100,000+ Students
have been Trained

since
1997



Diploma in CNC Programming

- Define machining operations
- Define Roughing operation
- Define Facing operation
- Define proofing willing operation
- Define surface willing operation
- Define Finishing operation
- Define Corner finishing operation
- Define Trajectory milling operation
- Define drilling cycles
- Define Boring Cycles
- Define Reaming cycles
- Define Tapping cycles
- Define parameters all operation
- Define Drilling cycles on 5 axis
- Define trajectory milling on 5 axis
- Define Engraving on 5 axis
- Define proofing milling on 5 axis
- Define roughing cycle on 5 axis
- Define cutline milling on 5 axis
- How to make mill window
- How to make mill volume
- How to make mill surface
- How to apply post processor
- Tool simulation (vericut)
- Creation of NC Files



Diploma in CNC Programming

100,000+ Students
have been Trained

since
1997



TERMS & CONDITIONS

WITHDRAWAL FROM THE DIPLOMA/CERTIFICATION

Students are not allowed to withdraw from the Diploma. If a student cannot continue the Diploma his/her fee will be forfeited.

CONDUCT AND DISCIPLINE

A disciplinary action, leading to rustication, will be taken against students whose conduct is found objectionable at any time during the course of study. Reference will be made to 3D Educators code of conduct.

EVALUATION AND GRADING

The performance of students is evaluated through continuous observation of a student's performance in the Diploma – class participation, submission of assignments, quizzes and exercises.



Diploma in CNC Programming

100,000+ Students
have been Trained

since
1997



The student will be examined through three hourly exams conducted at the midterm and a final exam at the end of the program. Total marks for passing the Diploma will be 60 out of a total of 100.

Students who do not meet the attendance or any other eligibility criteria will not be allowed to appear in the final examination.

The following grading plan will be applicable for the Diploma:

A	87 - 100
B+	81 -86
B	72 - 80
C+	66 - 71
C	60 - 65
F	below 60



Diploma in CNC Programming

100,000+ Students
have been Trained

since
1997



Students who are unable to appear for the final exam are required to submit a written application stating the reason for not appearing for the exam. 3D Educators reserves the right to approve or deny such applications. If approved, the student will be allowed to sit for the exam within one month. Failure to do so, the student will be resubmit the examination fee and sit the future schedule exam. Without passing of the exams no certification will be awarded.



Diploma in CNC Programming

100,000+ Students
have been Trained

since
1997



ONLINE LIVE CLASSES FACILITY AVAILABLE

- Instructor Led Training
- Real Time Presentations
- Interactive Classes
- Complete Notes and Other Stuff shall be provided through our Secure Student Login Member's Area
- For Online Live Classes, you may please download the Admission Form through our website <http://www.3deducators.com>. Fill it properly and attached the required document along with Picture and send back to info@3deducators.com with scanned fee submitted voucher in the bank.
- For Pakistan you may submit the fee at any MCB Branch with the title of "3D EDUCATORS-TRAINERS & CONSULTANTS".
- If you are outside Pakistan then you may transfer via Bank to Bank or any western union, Fast Track, Money Gram or else International Transfer Body.
- After Admission, if you don't have GMAIL Account then you are requested to kindly make one GMAIL Account and shared it info@3deducators.com. Then further correspondence shall be made by our institute official.
- Extra Bandwidth Charges shall be incurred.

DISTANCE NOT MATTER

You can join in the live classes Sessions of 3D EDUCATORS – TRAINERS & CONSULTANTS from anywhere of the world.



Diploma in CNC Programming

100,000+ Students
have been Trained

since
1997



PRECAUTIONARY MEASURES

- During Classes, you are requested to make sure that you are in isolated room, where no noise should be there except your voice.
- Kindly Switch Off your Cell Phone during the class, because it will disturb the quorum of class.
- If you have taken the admission in the course online lonely, then ethically it is recommended and suggested that you alone in the class.
- Recording of Lectures are not allowed at your end.

This world is emerging and growing in the 21st Century very rapidly because of latest and remarkable technologies and its advancement. Due to advancement of technology, we 3D EDUCATORS offer Live Interactive class sessions

3D EDUCATORS believe on Information Technology and its systems. Now you can also avail this facility at your home.

CONTACT US

+9221-34141329, +9221-34857148
+92 333-2402474

info@3deducators.com
<http://www.3deducators.com>

Get the Admission Form

Download Form 

**MANAGEMENT
3D EDUCATORS
TRAINERS & CONSULTANTS**